



EUROPEAN
COMMISSION

Community research

MICROGRIDS – Novel Architectures for Future Power Systems

Paris, France, 29 January 2010

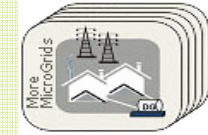

MICROGRIDS Workshop

General Theme:

The workshop aims to demonstrate the ways to increase the penetration of distributed generation including micro-generation in electrical networks through the exploitation and extension of the Microgrids concept. This novel distribution network architecture proves the most efficient way to unlock the full potential of Distributed Generation via efficient control strategies and alternative network designs. Financial and regulatory issues are key for this development and will be extensively discussed.

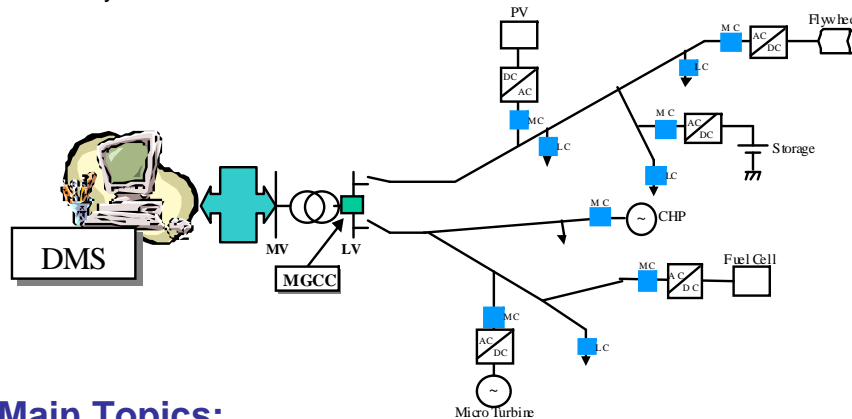

Main Topics:

- What are Microgrids? What distinguishes Microgrids from Distribution feeders with DGs?
- What are the differences between Microgrids and Virtual Power Plants?
- What are the economic and environmental benefits of Microgrids in network operation?
- How to technically manage several Microgrids on a same MV network?
- Can Microgrids provide ancillary services (Voltage control, islanding, blackstart)?
- What control and management architectures should be used?
- What are the technical benefits of Microgrids operation?
- Can Microgrids displace central generation? Can they defer investments in networks?
- What are the key technical challenges in Microgrids operation?
- What are the regulatory barriers?
- Are Microgrids profitable? For whom?
- Lessons learned from running pilots

Invited Speakers:

In the workshop results from international RD&D activities will be presented by invited speakers from the EU More Microgrids, the US CERTS Microgrids projects, etc.

Location:

Auditorium of SAP France S.A., DEFENSE PLAZA, 23-25, rue Delariviere Lefoullon, 92064 PARIS LA DEFENSE CEDEX, phone: +33(1) 44452000

Information - Registration :

ICCS-NTUA,

- Mrs Eleni Avlonitou, eavlon@power.ece.ntua.gr, phone: +30-210-7723699
- Mrs Irene Gasparak, igasp@power.ece.ntua.gr, phone: +30-210-7723836

Registration Deadline:

15th January 2010

Supporting Organisations

ICCS-NTUA (GR, More Microgrids Project Coordinator)

- | | |
|------------------------------------|--|
| ABB SCHWEIZ AG (CH) | INESC-PORTO (PT) |
| ALLIANDER (NL) | LABELIN – TECNALIA (ES) |
| ANCO S.A. (GR) | MVV ENERGIE AG (DE) |
| ARMINES (FR) | SIEMENS AG (DE) |
| BIOENGINEERING DOO (FYROM) | SMA TECHNOLOGIE (DE) |
| CRES (GR) | SYSTEMS SUNLIGHT S.A. (GR) |
| DANMARKS TEKNISKE UNIVERSITET (DK) | SS CYRIL AND METHODIUS UN. (FYROM) |
| EDP S.A. (PT) | TURBO POWER SYSTEMS Ltd. (GB) |
| EMFORCE B.V. (NL) | UNIVERSITY OF LODZ (PL) |
| ERSE (IT) | UNIVERSITY OF MANCHESTER (GB) |
| FRAUNHOFER IWES (DE) | ZIV P MAS C (ES) |
| ICEIM-MANU (FYROM) | ZAKLAD ENERGETYCZNY LODG-TEREN SA (PL) |
| IMPERIAL COLLEGE (GB) | |



EUROPEAN COMMISSION

Community research

MICROGRIDS – Novel Architectures for Future Power Systems

Paris, France, 29 January 2010

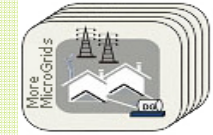

Preliminary Programme

General Overview:

09:00 – 09:10	Microgrids EU R&DD	P. Van Hove
09:10 – 09:30	Microgrids in the EU TP SmartGrids Context	M. Chebbo
09:30 – 09:40	Introduction to Microgrids	N. Hatzigiorgiou
09:40 – 10:00	Microgrids – The regulatory Challenge	G. Strbac
10:00 – 10:30	Microgrids – US Activities	Ch. Marnay

10:30 – 11:00 Coffee Break

Technical, Economical and Environmental Benefits:

11:00 – 11:30	Technical, Economic and Environmental benefits of Microgrids Operation	Ch. Schwaegerl
11:30 – 12:00	Impact of Microgrids on Network Planning (investment and replacement strategies)	P. Mancarella

Technical Challenges I:

12:00 – 13:00	Micro source and storage controllers to provide efficient operation of Microgrids	D. Geibel, F. Van Overbeeke, T. Lakin, Ch. Hardt, others?
---------------	---	---

13:00 – 14:00 Lunch break

Technical Challenges II:

14:00 – 14:30	Protection and Control Issues: Network Designs (protection, microsource solid state interfaces)	A.. Oudalov
14:30 – 15:00	Protection and Control Issues: Control strategies with emphasis on decentralized control	A. Dimeas

Multi-Microgrids:

15:00 – 16:00	Multi-Microgrids (coordinated voltage and frequency control, emergency functions and ancillary services)	J.A. Pecas Lopes N. Jenkins
---------------	--	--------------------------------

16:00 – 16:30 Coffee break

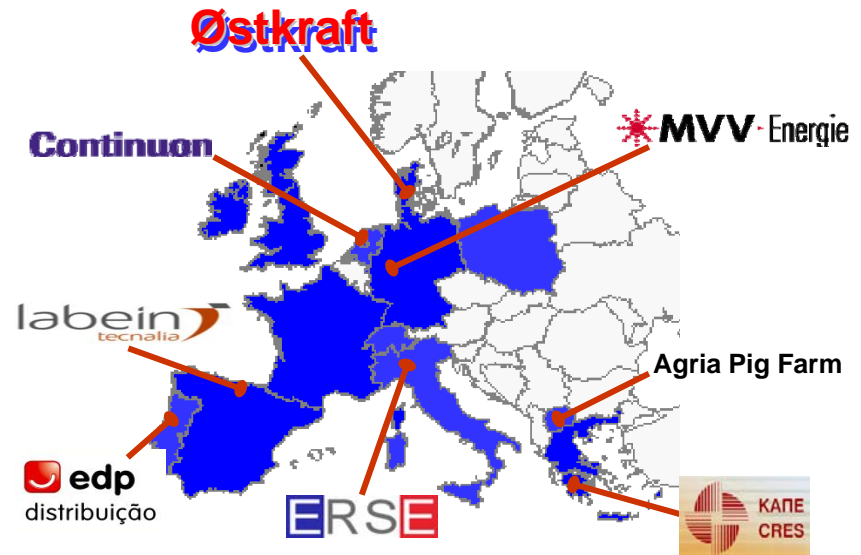

Microgrids Pilots – Lessons learned:

16:30 – 18:30	Overview	G. Kariniotakis
	The Kythnos Microgrid	S. Tselepis
	Mannheim-Wallstadt	B. Buchholz
	Bronsbergen Holiday Park	S. Cobben
	Bornhold island	J. Eli Nielsen
	EDP Microgrid	N. Melo
	Agria Pig Farm	R. Taleski
	Labein Laboratory	J. Oyarzabal
	ERSE Laboratory	O. Perego

18:30 – 19:00 Conclusions